

Important Safety Instructions

1. **Read and follow all instructions.**
2. **Save these instructions.**
3. Always be sure the unit is OFF and unplugged during installation or maintenance procedures.
4. The Ultraviolet light produced by UV lamp is harmful to your eyes.
5. Do not look directly at the lamp.

Unpacking the unit

Each monitoring system with UV lamp is shipped with the germicidal lamp placed in a tube with protective packaging. Carefully remove lamp from the tube taking care to not touch the glass portion of the lamp with bare hands. If you accidentally touch a lamp, wipe it off using a soft cloth dampened with rubbing alcohol. The lamp is fragile and proper care must be taken when handling from packaging.

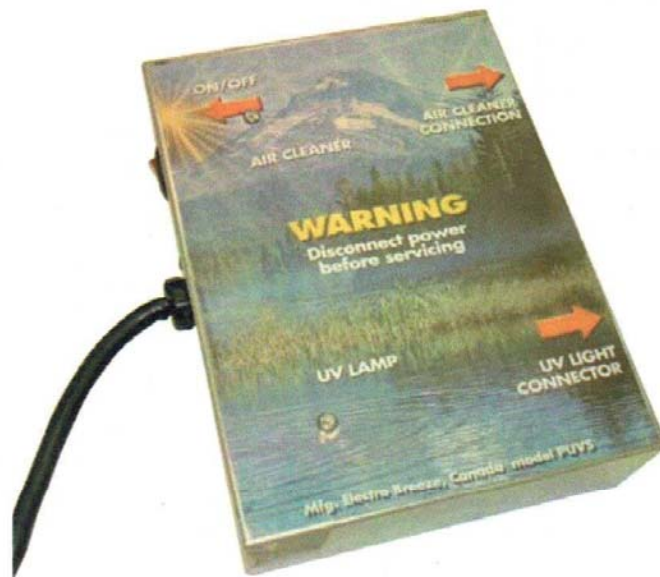

Wiring

The Electro Breeze UV/Filter Monitor is ready to work , no wiring is necessary, simply plug the monitoring sytem into a 120 volt outlet, plug the UV wire into the UV lamp and the Filter plug into the Filter electrical terminal. That is All.

Cautions

Do not touch the glass portion of the lamp with bare hands because oils from the hands can cause "HOT SPOTS" which reduce lamp life. Always wait 5 minutes after unplugging the lamp before servicing.

Maintenance on Electronic Air Cleaner

Please refer to attached sheet on the universal replacement Pads for polarized Electronic Air Cleaners.

To contact us

Electro Breeze Air cleaner Ltd.
Toll free: 1-877-821-2500
Fax: 450-226-3155
Web: www.electrobreeze.com
Email: info@electrobreeze.com

Installation Instructions for Duct mounted style

1st step:

Install the UV Filter monitor System on the return duct of the HVAC system about 4 feet over the ground. Use the back cover of the monitor as a template to locate the 4 mounting screw holes.

2nd step:

To install the UV support plate, use the installation template included in the instruction kit, locate the 4 mounting screw holes and draw the UV clearance hole about 12 inches over the filter monitor system to be able to cut it out. Then drill the 4 holes and cut out the UV clearance hole in the duct.

3rd step:

Fix the UV support plate (item 2) with the 4 metal screws provided (item 3). Insert the UV lamp in the central hole and fix the UV lamp holder (item 5) with the thumb nuts. (item 6)

4th step:

Connect the UV Filter Monitor System cable (grey wire) to the UV lamp. Connect the 24 volts (black flat wire) to the terminal on the air cleaner. Plug the 110 volts line into outlet. Turn the switch on (Red button).

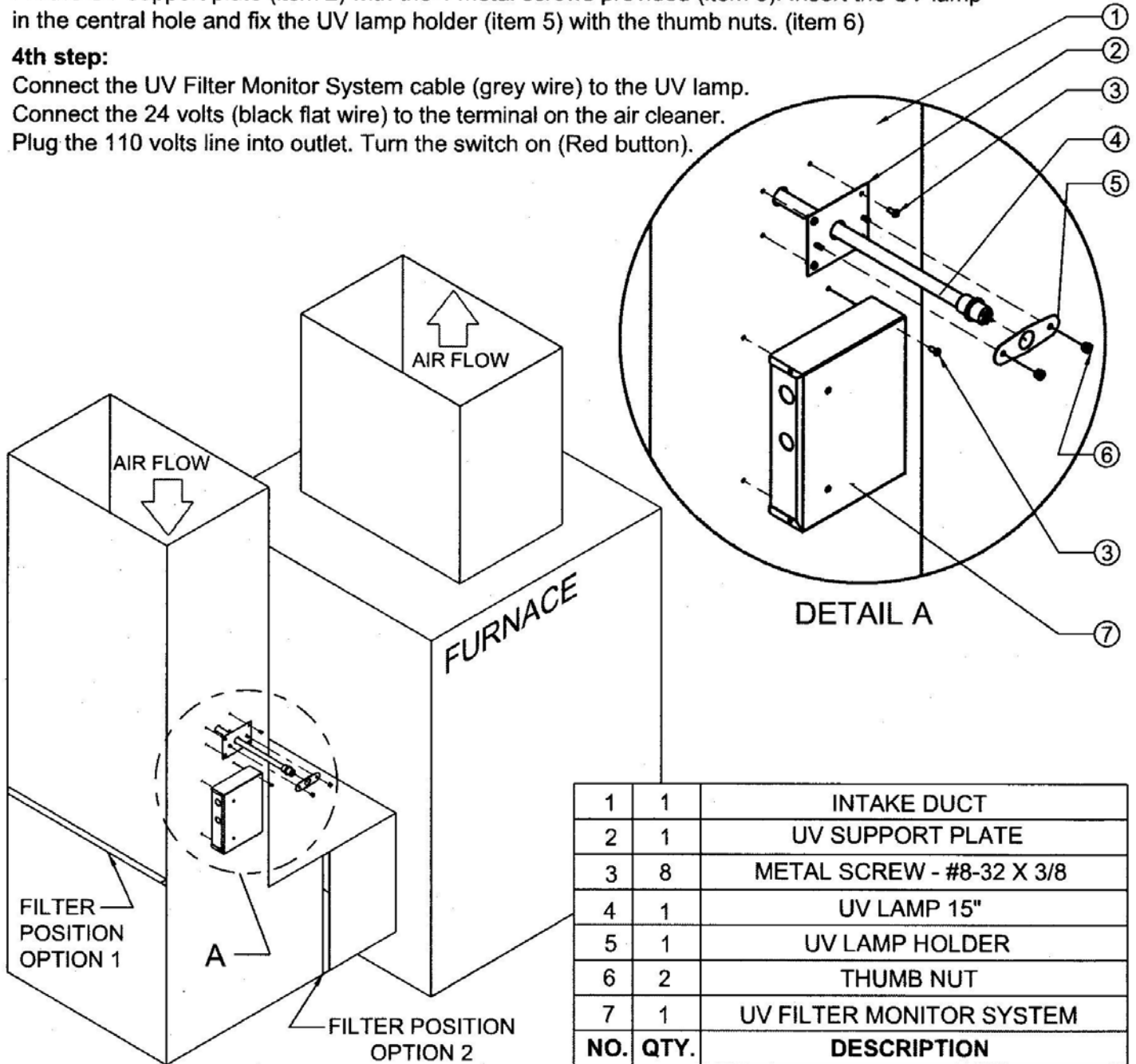

Installation Instructions for UV/Filter unit (P124UV model)

1st step:

Install the UV Filter Monitor System on the return duct of the HVAC system about 4 feet over the ground. Use the back cover of the monitor as a template to locate the 4 mounting screw holes (item #2).

2nd step:

Connect the UV Filter Monitor System cable (grey wire) to the UV lamp. Connect the 24 volt (black flat wire) to the terminal on the air cleaner, then plug the 110 volts line into outlet.

3rd step:

Slide the Electronic Air Cleaner (P124UV) inside the duct (item #4). Then turn on the switch (Red button).

